

strönd

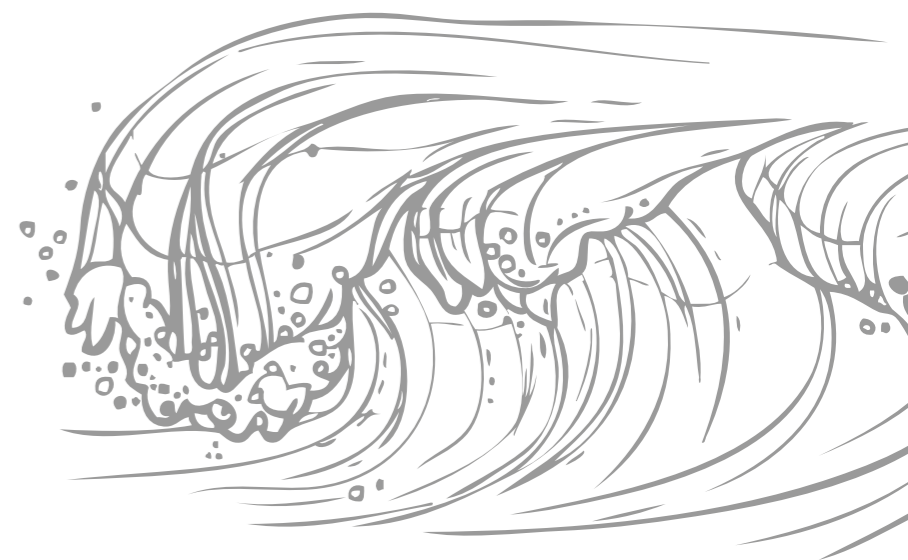

MUSEUM

MUSEUM



04

INNOVATION

06

THE STORY

10

THE COLLECTION

34

MIX&MATCH

36

TECHNICAL INFO

Our innovative 4D TECH in large 100x100cm format reaches a 20mm thickness, to provide us with surfaces of extraordinary resistance for both residential and commercial areas.

It is a system adaptable to various outdoor surfaces, depending on whether it is installed on grass, sand, gravel, plots or with a traditional sealing system. Using the recommended gasket in each case.

The traditional porcelain sealing system is recommended in areas with medium-high pedestrian traffic or on surfaces or access ramps with vehicles.

Nuestra innovadora tecnología 4D en gran formato 100x100cm alcanza el espesor de 20mm, para proporcionarnos superficies de extraordinaria resistencia tanto para ámbito residencial como para ámbito comercial.

Es un sistema adaptable a diversas superficies de exterior, según si se instala sobre césped, arena, grava, plots o con sistema tradicional de sellado. Utilizando la junta recomendada en cada caso.

Se recomienda el sistema tradicional de sellado porcelánico en zonas de tránsito peatonal medio-alto o bien en superficies o rampas de acceso con vehículos.

resistance
resistencia

 **Break resistant**
Resistente a la rotura

 **Extreme weather resistant**
Resistente a climas extremos

 **Scratch resistant**
Resistente a rayaduras

 **Chemicals, acids, stains resistant**
Resistente a químicos, ácidos y manchas

awareness
conciencia

 **Ecofriendly**
Respetuoso con el medioambiente

 **Recycled and recyclable**
Reciclado y reciclable

 **Lower maintenance cost**
Menor coste de mantenimiento

aesthetics
estética

 **Chromatic stability**
Estabilidad cromática

installation
instalación

 **Easy installation, no sealing needed**
Fácil instalación, no necesita sellado

 **Indoor & outdoor**
Interior y exterior

 **Fast installation**
Colocación rápida

 **Easy replacement**
Fácil sustitución

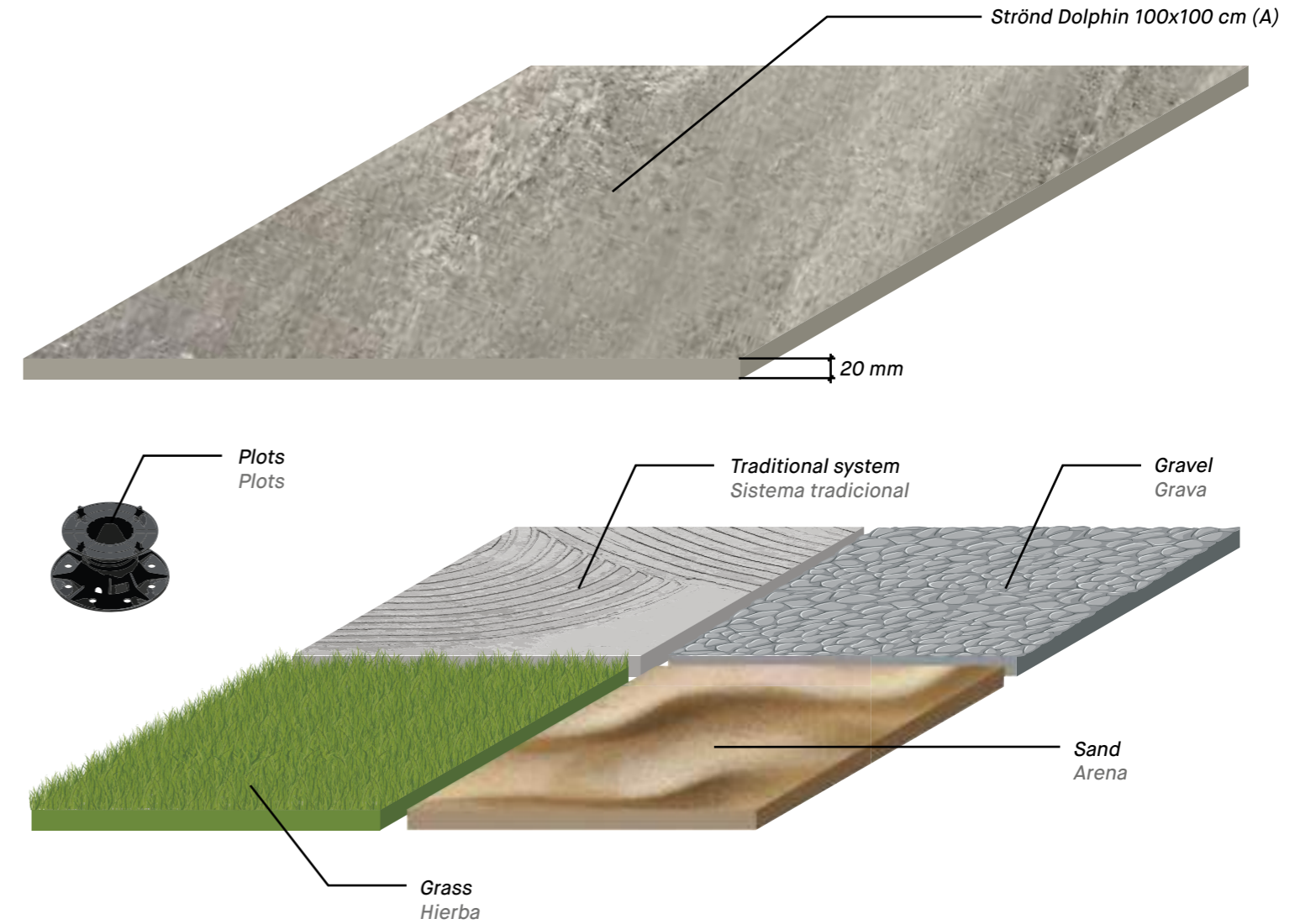

20 mm

Searching, finding, exploring new fields, going beyond limits. That's how we understand our world.

Inspired in the world's most remote beaches, innovation and wildness merge into this collection. This is Strönd. Come find it.

Buscar, encontrar, explorar nuevos caminos, ir más allá de los límites. Así es como entendemos nuestro mundo.

Inspirada en las playas más remotas del mundo, la innovación y la naturaleza se mezclan en esta colección. Esto es Strönd. Ven a encontrarla.

strönd

[beach] · icelandic

1.
A pebbly or sandy shore, especially by the sea between high- and low-water marks.

[playa] · islandés

1.
Extensión casi plana de arena o piedras en la orilla del mar, de un río o de un lago.







Strönd is inspired by the world's more secluded beaches. The tiles feature a mix of stone designs, with finer details in shades of varying intensities on each one. The collection's Shaped finish further enhances its realism and natural appeal.

The collection comes in a choice of 3 colours –Cloud, Oat and Dolphin– in a 100x260cm, 100x180cm, 100x100cm, 60x120cm or 90x90cm format. Thanks to the use of 4D technology, Strönd also includes an extra-thick 20mm model in a 100x100cm format for use outdoors.

La colección Strönd se inspira en las playas más recónditas del mundo. Representa un mix de gráficas pétreas con detalles de variedad tonal dentro de cada pieza, logrando mayor realismo gracias al acabado Shaped.

Disponible en tres colores diferentes: Cloud, Oat y Dolphin. En formatos 100x260cm, 100x180cm, 100x100cm, 60x120cm y 90x90cm. Además, gracias a la tecnología 4D ofrece como solución de exterior el espesorado de 20mm en formato 100x100cm.

GRAPHICS



GRAPHIC VARIETY: 9 patterns VARIEDAD GRÁFICA: 9 modelos

Strönd Dolphin 100x180 cm















100 x 260 cm



Finish // Acabado



Thickness // Espesor

6 mm

100 x 180 cm



Finish // Acabado



Thickness // Espesor

8 mm

100 x 100 cm

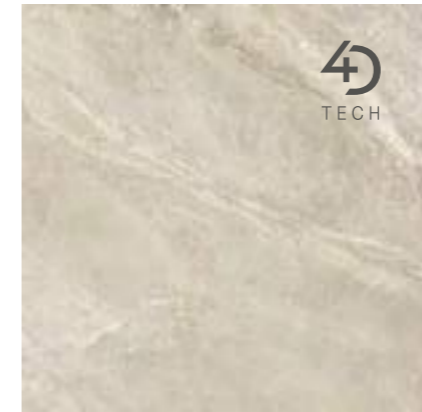

Finish // Acabado



Thickness // Espesor

8 mm

Finish // Acabado



Thickness // Espesor

20 mm

60 x 120 cm



Finish // Acabados



Thickness // Espesor

10 mm

90 x 90 cm



Finishes // Acabados



Thickness // Espesor

10 mm



cloud



oat



dolphin



COLOURS



shaped

Smooth texture, the graphic is perfectly coordinated with the relief.

Textura suave, la gráfica se coordina perfectamente con el relieve.



antislip

Textured surface with matte finish, recommended for outdoor use.

Superficie texturizada mate, recomendada para uso exterior.



mist



Mist, an oak-effect collection with a chic timeless appeal, is the outcome of constant efforts to innovate.

Available in a 24x151cm format, the collection comes in a choice of a Shaped or Velvet finish. This last finish is the silkiest, most natural tile finish developed to date. Mist also features a choice of 5 warm colours: Maple, Dune, Honey, Kalua and Hazel.

A collection conceived to bring warmth and comfort to living spaces of all kinds, while also adding a select touch of sophistication.

De la constante búsqueda por la innovación, nace Mist, madera de roble natural con una estética atemporal y de lo más sofisticada.

En formato 24x151cm, y con dos acabados Shaped y Velvet. Este último representa la versión más suave y natural conocida hasta el momento en superficie cerámica. Su gama cromática se compone de 5 tonos cálidos: Maple, Dune, Honey, Kalua y Hazel.

Sin duda, la opción acertada para aportar calidez y comodidad a cualquier espacio sin renunciar a un estilo premium.



Porcelain Porcelánico

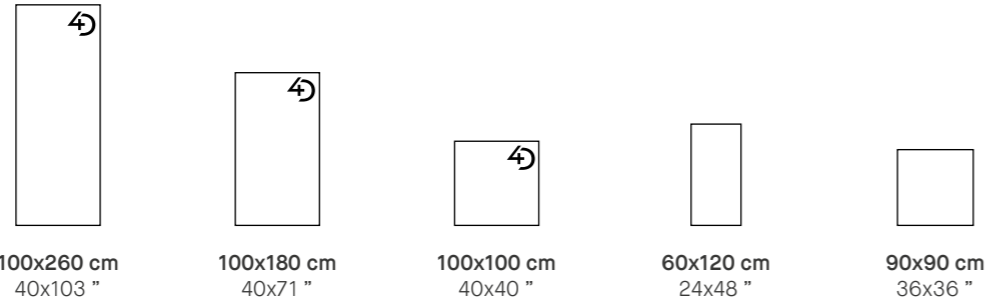

Thickness		6 mm	8 mm	8 mm / 20 mm	10 mm	
Patterns		5	9	15	20	15
Shade Variation		V1	V1	V1	V1	V1
CLOUD	Shaped (SP)	33113 M90	32861 M94	31761 M93	32852 M101	32855 M102
	Antislip (A)	-	-	32864 M113	-	32858 M81
OAT	Shaped (SP)	33115 M90	32863 M94	31763 M93	32854 M101	32856 M102
	Antislip (A)	-	-	32866 M113	-	32860 M81
DOLPHIN	Shaped (SP)	33114 M90	32862 M94	31764 M93	32853 M101	32857 M102
	Antislip (A)	-	-	32865 M113	-	32859 M81

SPECIAL PIECES // PIEZAS ESPECIALES

Porcelain Porcelánico (10 mm)

D. MOSAIC		30x30 cm 11.8x11.8 "	
	STRÖND CLOUD	Shaped (SP)	33090 U36
	STRÖND OAT	Shaped (SP)	33092 U36
	STRÖND DOLPHIN	Shaped (SP)	33091 U36

Porcelain Porcelánico (10 mm)

D. MIX		30x30 cm 11.8x11.8 "	
	STRÖND CLOUD MIST KALUA	Shaped (SP)	33219 U55
	STRÖND OAT MIST HONEY	Shaped (SP)	33220 U55
	STRÖND DOLPHIN MIST HAZEL	Shaped (SP)	33221 U55

TECHNICAL DATA // DATOS TÉCNICOS

	DIN 51130	DIN 51097	UNE-41901 EX	BS 7976-2 (PTV)	ANSI A137.1 (DCOF)
Shaped (SP) 6-8 mm	-	-	Class 1	-	>0,42 Wet
Shaped (SP) 10 mm	R10	A + B	Class 2	+36 Wet	>0,42 Wet
Antislip (A)	R11	A + B + C	Class 3	+36 Wet	>0,42 Wet

COMPLEMENTARY PIECES // PIEZAS COMPLEMENTARIAS

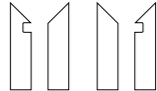
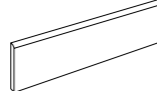
S.K.I. S.K.D.		SKIRTING				
	8x30 cm 3.1x11.8 "		8x100 cm 3.1x39.4 "	8x90 cm 3.1x35.4 "	8x60 cm 3.1x23.6 "	
Shaped (SP)	U53	Shaped (SP)	U45	U44	U35	
Antislip (A)	U53	Antislip (A)	-	U44	-	

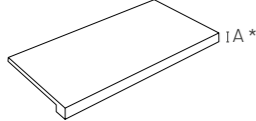
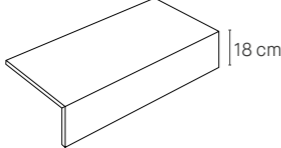
STAIR TREADS		* When thickness is 8 mm, A = 24 mm; when 10 mm, A = 30 mm. * Cuando el espesor es 8 mm, A = 24 mm; cuando es 10 mm, A = 30 mm.				
TECHNICAL (PT)	SEAMLESS (PL/18)					
		30x180 cm 11.8x70.8 "	30x120 cm 11.8x47.2 "	30x100 cm 11.8x39.4 "	30x90 cm 11.8x35.4 "	30x60 cm 11.8x23.6 "
Shaped (SP)		U90	U75	U74	U76	U54
Antislip (A)		-	-	-	U76	-

POOL PIECES // PIEZAS DE PISCINA

Porcelain Porcelánico

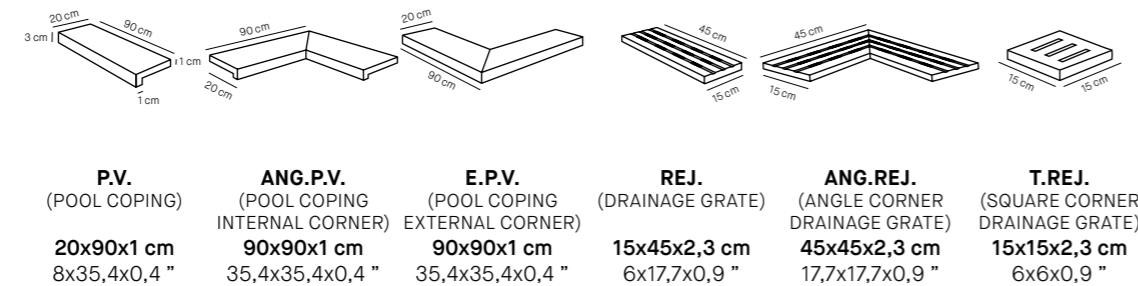

		P.V. (POOL COPING) 20x90x1 cm 8x35,4x0,4 "	ANG.P.V. (POOL COPING INTERNAL CORNER) 90x90x1 cm 35,4x35,4x0,4 "	E.P.V. (POOL COPING EXTERNAL CORNER) 90x90x1 cm 35,4x35,4x0,4 "	REJ. (DRAINAGE GRATE) 15x45x2,3 cm 6x17,7x0,9 "	ANG.REJ. (ANGLE CORNER DRAINAGE GRATE) 45x45x2,3 cm 17,7x17,7x0,9 "	T.REJ. (SQUARE CORNER DRAINAGE GRATE) 15x15x2,3 cm 6x6x0,9 "
CLOUD	Antislip (A)	33877 M81	33880 M75	33883 M75	33886 M54	33895 M75	33898 M71
OAT	Antislip (A)	33879 M81	33882 M75	33885 M75	33894 M54	33897 M75	33899 M71
DOLPHIN	Antislip (A)	33878 M81	33881 M75	33884 M75	33893 M54	33896 M75	33900 M71

PACKING // PACKING

SIZE // FORMATO	BOX // CAJA			PALLET			CONTAINER 20' (24000 Kg.)			
	Piezas	m ²	kg	Cajas	m ²	kg	largo x alto x ancho	N° pallets	m ²	kg
100 x 180 x 0,8	2	3,6	70,25	18	64,8	1315	190 x 115 x 60	17	1101,6	22347
100 x 100 x 0,8	2	2	36,8	32	64	1220	112 x 112 x 100	19	1216	23172
100 x 100 x 2	1	1	49,2	24	24	1223	112 x 112 x 100	19	456	23237
60 x 120 x 1	2	1,44	33,18	27	38,88	921	120 x 80 x 75	26	1010,8	23942
90 x 90 x 1	2	1,62	37,96	22	35,64	860	105 x 95 x 75	27	962,3	23223
inch	Units	ft ²	lb	Boxes	ft ²	lb	length x height x width	N° pallets	ft ²	lb
39,4 x 70,8 x 0,32	2	38,75	154,87	18	697,5	2900	71.2 x 44.1 x 25.2	17	11857.5	49267
39,4 x 39,4 x 0,32	2	21.53	81.13	32	688.9	2690	44.1 x 44.1 x 39.4	19	13088.9	51086
39,4 x 39,4 x 0,78	1	10.76	108.47	24	258.3	2696	44.1 x 44.1 x 39.4	20	4908.3	51229
23,6 x 47,2 x 0,39	2	15.50	73.15	27	418.5	2030	47.2 x 31.4 x 29.5	26	10880.2	52783
35,4 x 35,4 x 0,39	2	17.44	83.68	22	383.6	1896	41.3 x 37.4 x 29.5	27	10357.9	51198

SLABS PACKING // PACKING DE PLACAS

SIZE // FORMATO	SLAB // PLACA			WOODEN CRATE // CAJÓN MADERA			CONTAINER 20' (24000 Kg.)			
	Piezas	m ²	kg	Placas	m ²	kg	largo x alto x ancho	Cajones	m ²	kg
100 x 260 x 0,6	1	2,6	36,4	20	52	826,8	278 x 31 x 112 cm	24	1248	19843,2
inch	Units	ft ²	lb	Slabs	ft ²	lb	length x height x width	Crates	ft ²	lb
39,4 x 102,4 x 0,24	1	28	80.25	20	559.7	1822.8	109.4 x 12.2 x 44 "	24	13433.4	43746.8

WOODEN CRATE
CAJÓN MADERA

278 x 31 x 112 cm

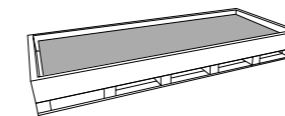

20 slabs placas

20' CONTAINER
optimal load capacity:
Capacidad de carga óptima
del CONTENEDOR 20':

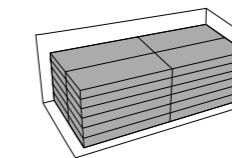

24 crates cajones
6 levels niveles

MUSEUM

Once ceramic tiles reach the end of their useful life, they are inert waste. For their proper management, they should be given to an authorized waste management body for recycling purposes.

All colours and hues appearing in this catalogue should be considered approximate, only in view of the printing processes involved. The rights of all contents (texts, photographs, drawings, designs, etc.) of this catalogue remain the property of PERONDA GROUP S.A (or, failing that, they have the corresponding permissions of the owners). No part of this publication may be reproduced, stored in a retrieval system, or transmitted in any form or by any means, electronic, mechanical, photocopying, recording or otherwise, without the prior written permission of the copyright holders.

© PERONDA GROUP 2022

Las baldosas cerámicas una vez que llegan al final de su vida útil son un residuo inerte, que para su correcta gestión debe ser entregado a un gestor autorizado de residuos, favoreciendo su reciclado.

Av. Manuel Escobedo, 26
12200 Onda (Castellón) Spain
+34 964 602 012

Debido a los procesos de impresión, los colores que aparecen en este catálogo deben considerarse aproximados, y no exactos. Los derechos de todos los contenidos (textos, fotografías, dibujos, diseños etc) del presente catálogo son propiedad de PERONDA GROUP, S.A (o en su defecto, cuentan con los correspondientes permisos y autorizaciones de sus titulares). No está permitida la reproducción total o parcial de esta publicación, ni su tratamiento informático, ni la transmisión de ninguna forma o por cualquier medio, ya sea electrónico, mecánico, por fotocopia, por registro u otros medios, sin el permiso previo y por escrito de los titulares del copyright.

museumsurfaces.com

